

CERAMIC TRIMMER CAPACITOR – 6MM

Suntan®

DISCONTINUED

FEATURES

As well as applications to small sized electronic apparatus, this series is designed for easy handling and is available with a variety of adjustment method (top, bottom, side and double sides).

- Wide mounting sizes and types of adjustment available
- Lots of capacity ranges, 2pF through 90pF
- Sturdy mechanical structure against vibration or shock

TSC6

(S, R) SERIES

SPECIFICATIONS

INSULATION RESISTANCE	10 MΩ at 250VDC
WITHSTAND VOLTAGE	400VDC
WORKING VOLTAGE	200VDC
ROTATION TORQUE	30 to 200 gf-cm
OPERATING TEMPERATURE	-30°C to +85°C



• STRAIGHT TYPE

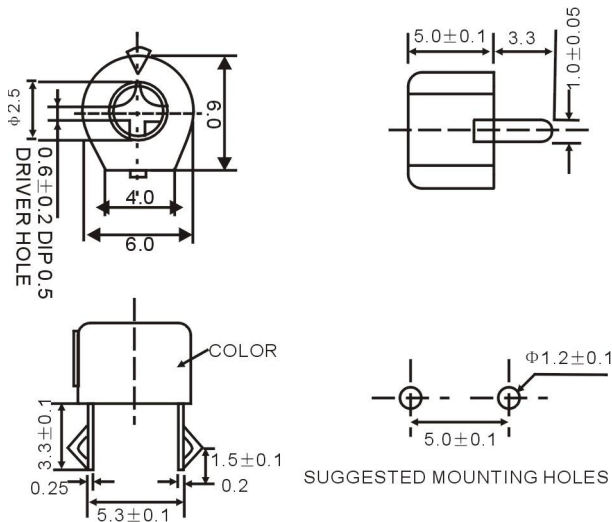

• REARADJUSTING TYPE

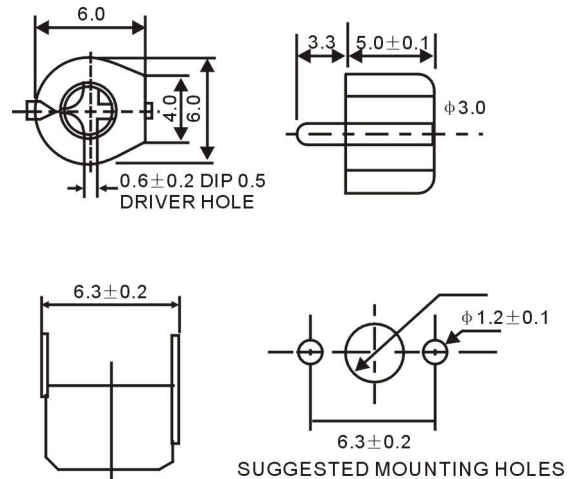

UNIT:MM

PART NO.	MIN. CAP. (PF)	MAX. CAP. (PF)	TEMP. COEFF. PPM/°C	Q FACTOR @ 1MHz Cmax	COLOR
TSC (S,R)06-050	2.0±50%	5 ⁺¹⁰⁰ ₋₀ %	NPO ± 200	>500	BLUE
TSC (S,R)06-100	3.0±50%	10 ⁺¹⁰⁰ ₋₀ %	N450 ± 300	>500	WHITE
TSC (S,R)06-200	4.2 ⁺¹⁰⁰ ₋₅₀ %	20 ⁺¹⁰⁰ ₋₀ %	N450 ± 300	>500	RED
TSC (S,R)06-300	6.2 ⁺¹⁰⁰ ₋₅₀ %	30 ⁺¹⁰⁰ ₋₀ %	N750 ± 500	>500	GREEN
TSC (S,R)06-400	6.8 ⁺¹⁰⁰ ₋₅₀ %	40 ⁺¹⁰⁰ ₋₀ %	N1200 ± 500	>300	YELLOW
TSC (S,R)06-500	9.8 ⁺¹⁰⁰ ₋₅₀ %	50 ⁺¹⁰⁰ ₋₀ %	N1200 ± 500	>300	BROWN
TSC (S,R)06-600	12 ⁺¹⁰⁰ ₋₅₀ %	60 ⁺¹⁰⁰ ₋₀ %	N1200 ± 500	>200	BROWN

Note 1 : Not applicable for reflow soldering method

Note 2 : During the soldering process, the ambient temperature in upper level of the oven can not be higher than 150 °C to avoid plastic part deformation may affect product performance

Note: Specification are subject to change without notice. For more detail and update, please visit our website.