

SLIDE SWITCH

Suntan®

TSS-SS-12D01

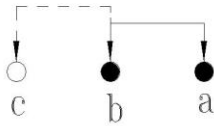
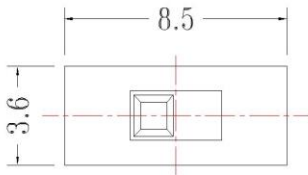

SCHEMATIC

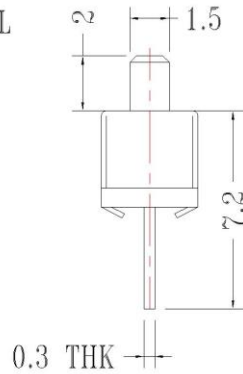
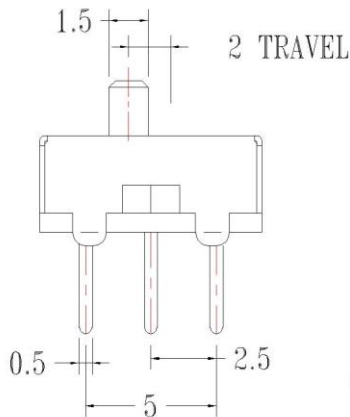

Note:THK means Thickness

MODEL NO	H (mm)
TSS-SS-12D01	2

CODE	OPERATING FORCE(gf)
Z	250gf ±100gf

No dimensional tolerances specified	
≤1	±0.1
1 ~10	±0.2
10 ~ 100	±0.3
>100	±0.5
Angel	±3°

SPECIFICATION:

1. RATING:DC 50V 30mA
2. CONTACT RESISTANCE:100m MAXΩ.
(INITLAL).
3. INSULATION RESISTANCE:100mΩ MIN.AT
250V DC.
4. WITHSTAND VOLTAGE:AC 500V FOR 1
MIN
5. DIP SOLDERING:230±5°C TEMPERATURE,
5±1SECOND
6. MANUALSOLDERING:350±10°C
TEMPERATURE,3±1SECOND
7. OPERATING FORCE:-20 °C to +80 °C
8. SWITCHING LIFE:10,000 CYCLES

Note: Specification are subject to change without notice. For more detail and update, please visit our website.